

## 3.4 METAL FASCIA SYSTEM

### 3.4.1 PRODUCT TECHNICAL STATEMENT

#### (a) Statement of Building Code Compliance

##### NZBC Compliance

Test information available from Pacific Coilcoaters and BHP NZ Steel, and past history of fascia systems, indicate that provided the product use and maintenance is in line with the guidelines contained in the current literature referenced, Dimond Rainwater Disposal Systems can be expected to meet the performance criteria in Clause E2 of the New Zealand Building Code, for a period of not less than 5 years.

##### Use Outside the Stated Guidelines

If the need arises to use Dimond Rainwater Disposal Systems outside the limitations and procedures given in this or other referenced literature, or, if any doubt exists on product handling or use, written approval for use must be obtained from Dimond, before the project commences.

#### (b) Scope of Use

Dimond Fascia 147, 185 and 195 are coated steel fascia systems intended for use as fascia and barge boards to support gutter systems, covering roof truss ends and gable ends around the roof perimeter on timber trussed residential buildings. External gutters are then fixed directly to the fascia to allow collection and discharge of rainwater.

Suitable for use with longrun metal roofing, metal tiles or concrete tiled roofs. Reference should be made to Section 2.1.1.2 Environments, to ensure the correct coated material on the fascia is chosen for the environment.

Dimond do not recommend fascia systems are used in very severe marine or geothermal environments as fascia is not available in plain aluminium, AR8, ARX, stainless steel or copper.

Typically 185 and 195 panel is used up the gable ends while 147 panel is used along the front.

#### (c) Consenting Instructions

Metal fascia systems have been used successfully on timber trussed residential buildings for the last 20 years.

For consenting it is important to check the correct prepainted finish has been selected for the environment. Refer to Section 2.1.1.2.

The gutter size should be chosen for its water carrying capacity in accordance with Section 3.1.4 and should ensure the size of the bracket and gutter can physically fit the panel depth.

### 3.4.2 DESCRIPTION

Dimond coated steel fascia systems are available in 147mm, 185mm and 195mm high panel, roll formed in 0.55mm BMT zincalume with a prepainted finish only. Unpainted zincalume product, copper, stainless steel and aluminium are not available.

The outer edge of the soffit lining is retained at the bottom of the fascia in a rolled groove.

### 3.4.3 DESIGN INSTRUCTIONS

- The set out of the fascia support brackets are shown in the construction details in Section 3.4.4.
- Level or sloping soffits up to 22.5° pitch can be used.
- Brackets are nailed or screw fixed to the soffit bearer or rafters when sloping soffits are used.
- The recommended set out heights must be maintained to avoid birds and vermin entering the roof space.
- Steel products should not come into contact with concrete and must avoid dissimilar metal contact.
- When selecting the gutter to use with the fascia system it is important to:
  - i) Consider the catchment area draining into the gutter (called flow load) to ensure the capacity of the gutter (called flow capacity) has not been exceeded. Refer to Section 3.1.4 for the method.
  - ii) Ensure the gutter with bracket can physically fit onto the fascia vertical face, laid to a fall of a minimum 1:500 and give an acceptable appearance. If not, select another smaller gutter size.

### 3.4.4 CONSTRUCTION INSTRUCTIONS

Selection of metal fascias needs to be made before the trusses are manufactured as the set out dimension may vary between the different systems available.

- Builders must ensure the timber soffit bearers are correctly set out using the published guidelines for the roof type being used prior to the fascia installation.
- Fascia brackets are nailed or screwed onto the soffit bearers to a level and true alignment using a string line.
- 6m maximum length of fascia are then fitted to the fascia brackets, cut back in length where necessary, and lengths joined together using normal roofing practice with silicone sealant and 4mm diameter rivets at 150mm maximum centres. Corner soakers are fitted over the fascias and rivetted on to cover corner joints.
- Metal fascia are specialised system that require specialised installers. Metal roofers do not normally install fascia. We do not recommend, support or approve DIY installations. Specialist companies throughout New Zealand install Dimond fascia. Contact Dimond for a list of installers in your area. Phone 0800 Dimond (0800 34 6663).

### 3.4.4.3 FASCIA 185 INSTALLATION GUIDE

#### METAL TILES AND METAL ROOFS

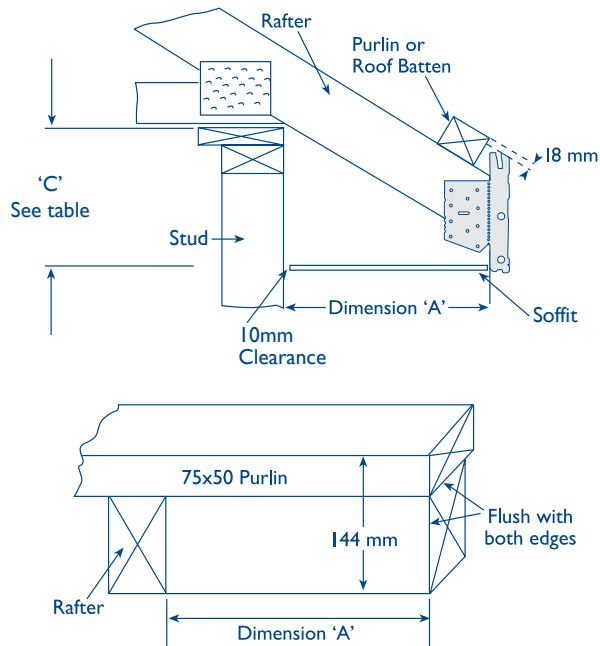

#### Hip & Gable Roof – Eaves Detail

Soffit Width mm	300	450	600
Dimension 'A' mm	295	445	595

#### Note:

- 94x47 soffit bearers used unless stated.
- Soffit bearers fixed to right or left hand side of rafter.
- 10 mm clearance allowed for soffit.

#### Gable End Detail

Soffit Width mm	300	450	600
Dimension 'A' mm	295	445	595

In heavy snowfall and wind areas, brackets and snow straps must be fixed at 450 mm centres. In medium wind areas it is advisable to fix the brackets at 600 mm centres.

Roof Pitch (Degrees)	Drop Heights – Dimension C (mm) Soffit widths (mm)			
	300	450	600	750
<b>10</b>	95	123	151	179
<b>12.5</b>	107	140	173	206
<b>15</b>	120	160	200	240
<b>17.5</b>	133	180	227	274
<b>20</b>	145	200	254	309
<b>22.5</b>	160	222	284	346
<b>25</b>	173	243	313	383
<b>27.5</b>	188	266	344	422
<b>30</b>	202	289	376	463
<b>35</b>	233	338	443	548
<b>40</b>	268	394	520	646
<b>45</b>	306	456	606	756
<b>50</b>	350	529	708	887

#### Notes for Installers

1. To ensure birds cannot enter the roof space, there should be no gap between the bottom purlin and the back face of the gutter after the system has been installed.
2. NOTE: Soffit bearers are required on all hip corners and should be cut back 10 mm.
3. Where loose fill insulation is used, the soffit must be blocked off at the top plate to prevent the insulation coming into contact with the metal fascia.
4. Zinalume coated gutters should have a minimum fall of at least 1:500 and should not have permanent ponding. Check with your nearest distributor for further details.

### 3.4.4.4 FASCIA 185 & GUTTER INSTALLATION GUIDE

#### CONCRETE TILE ROOFS

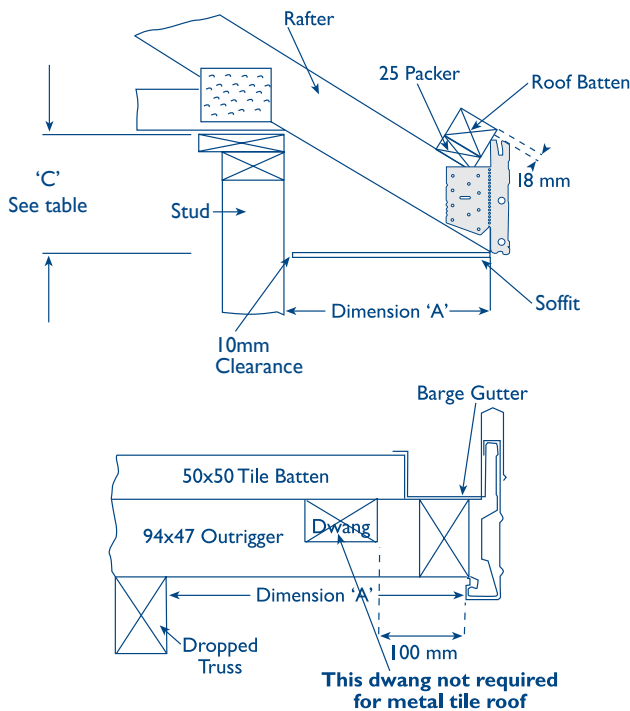

#### Hip & Gable Roof – Eaves Detail

Soffit Width mm	300	450	600
Dimension 'A' mm	295	445	595

#### Note:

- 94x47 soffit bearers used unless stated.
- Soffit bearers fixed to right or left hand side of rafter.
- 10 mm clearance allowed for soffit.

#### Gable End Detail

Soffit Width mm	300	450	600
Dimension 'A' mm	295	445	595

In heavy snowfall and wind areas, brackets and snow straps must be fixed at 450 mm centres.  
In medium wind areas it is advisable to fix the brackets at 600 mm centres.

Roof Pitch (Degrees)	Drop Heights – Dimension C (mm) Soffit widths (mm)			
	300	450	600	750
<b>17.5</b>	107	154	201	248
<b>20</b>	118	173	227	282
<b>22.5</b>	133	195	257	319
<b>25</b>	145	215	285	355
<b>27.5</b>	160	238	316	394
<b>30</b>	173	260	347	434
<b>35</b>	202	307	412	517
<b>40</b>	235	361	487	613
<b>45</b>	271	421	571	721

#### Notes for Installers

1. To ensure birds cannot enter the roof space, there should be no gap between the bottom purlin and the back face of the gutter after the system has been installed.
2. Colorflo 185 mm External Fascia and Gutter is not suitable on concrete tile roofs with sloping soffits.
3. NOTE: Soffit bearers are required on all hip corners and should be cut back 10 mm.
4. The use of concrete tiles on the barge ends is not a recommended practice as highlighted in the NZ Metal Roofing and Cladding Code of Practice Section 2 under Compatibility 2.7.2. Should people continue to use this method then there should be some sort of barrier between the two and there is no warranty offered by Pacific Coil Coaters or New Zealand Steel for corrosion if this method is used. This means that all installations should have a bottom batten around the edge of the roof line rather than let the concrete tile rest on the fascia.
5. Where loose fill insulation is used, the soffit must be blocked off at the top plate to prevent the insulation coming into contact with the metal fascia.
6. Zinalume coated gutters should have a minimum fall of at least 1:500 and should not have permanent ponding. Check with your nearest distributor for further details.

### 3.4.7 MAINTENANCE REQUIREMENTS

Regular washing of all surfaces not normally washed by rainfall (called 'unwashed areas') needs to be done with clean fresh water. Regular washing may be anything from 3 monthly to 12 monthly periods. Washing should either be with a stiff soft bristled brush or water blasting at a pressure of 1500-2000 psi.

Care needs to be taken to avoid driving water into the soffit ends and roof space, by working away from soffit joints.

Should the fascia panel or parts of it become corroded over time, it must be repaired when it is first noticed. We recommend the corrosion is neutralised, then corrosion cleaned off, fascia washed down to remove dirt, oils and any grease or silicone, before priming and applying two coats of acrylic roof paint to the paint manufacturer's recommendation.

Alternatively, badly corroded lengths should be replaced, but expect colour variations due to paint fade that may not be acceptable or aesthetically pleasing for the end user.

### 3.4.8 TEST RESULTS

Regular material quality tests are carried out by our coil suppliers to ASTM....

Dimond have tested 185 fascia for snow load to ensure it does not detach from the fixing brackets under a sliding 1.5 kPa snow fall on a 15° roof slope. The panel stayed attached to the fixing brackets.

### 3.4.9 QUALITY ASSURANCE

As part of Dimond's commitment to ensuring best quality and consistent manufacture, we run consistent quality checks on the products we produce to ensure the product meets our specifications for dimension tolerances.

### 3.4.10 PRODUCT SUPPORT

Contact details for Dimond:

National Sales: 0800 DIMOND (0800 346 663)

Technical: 0800 ROOFSPEC (0800 766 377)